

零件手册

Parts Book

1、机壳部件 ARM BED COMPONENTS

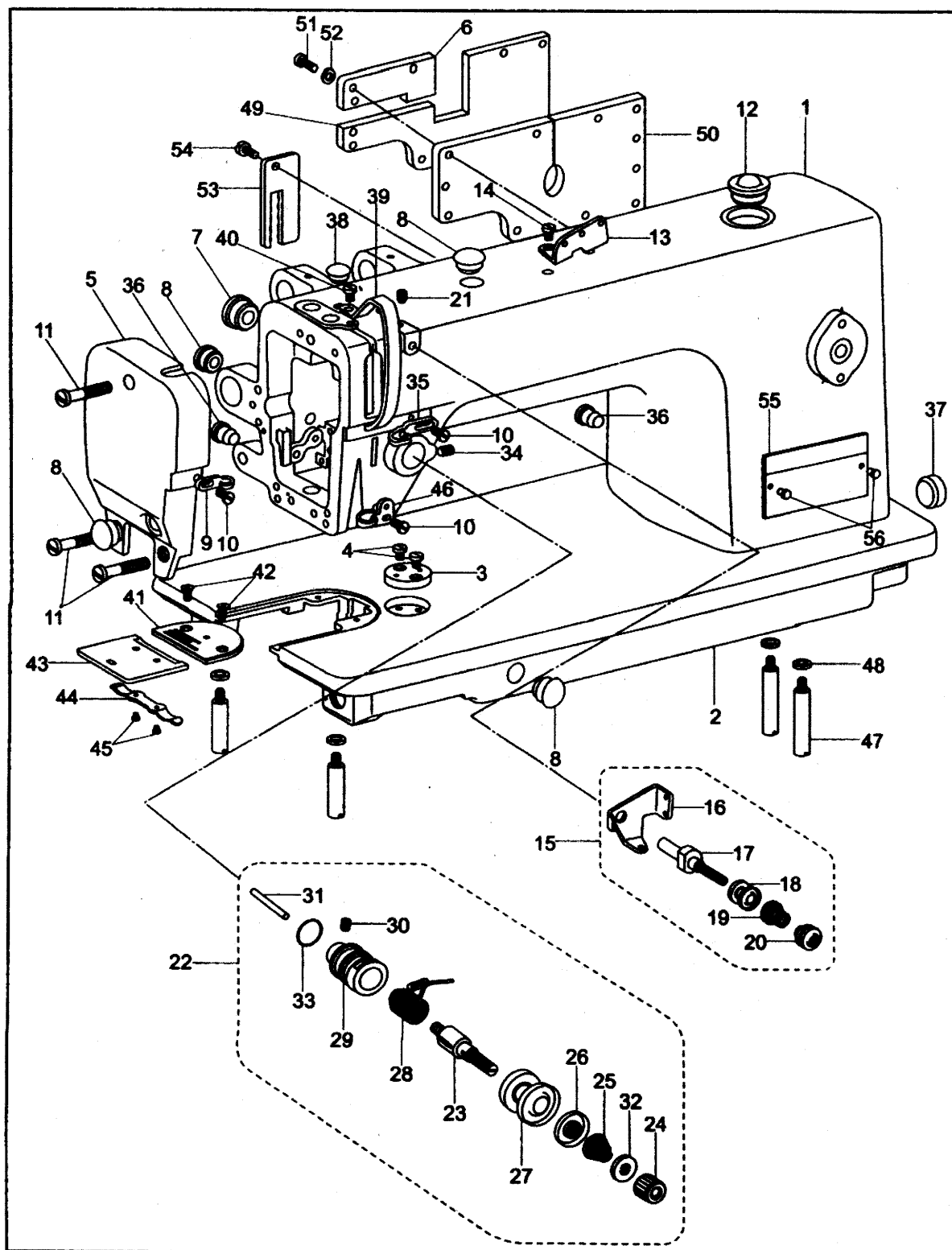

1、机壳部件 ARM BED COMPONENTS

序号 Ref. No	Description	名 称	数量 Qty	备 注 Memo
1	Arm	机壳	1	
2	Trade mark plate	底板	1	
3	Ruler plate	夹具座	1	
4	Screw	夹具座螺钉	2	
5	Face plate	面板	1	
6	Rear cover (small)	后盖板 (小)	1	
7	Oil cap	面板橡皮塞	1	Φ19
8	Oil cap	面板橡皮塞	4	Φ11.8
9	Face plate thread guide	面板线勾	1	
10	Screw	线勾螺钉	3	
11	Screw	面板螺钉	3	
12	Oil guide window	油窗组件	1	
13	Thread reatiner	三孔线勾	1	
14	Screw	三孔线勾螺钉	1	
15	Small thread tension arm	小夹线组件	1	
16	pre-thread guide disc	小夹线过线板	1	
17	Screw	小夹线螺钉	1	
18	Thread guide disc	小夹线板	2	
19	Spring	小夹线弹簧	1	
20	Nut	小夹线螺母	1	
21	Screw	小夹线固定螺钉	1	
22	Thread tension arm	夹线组件	1	
23	Screw	夹线螺钉	1	
24	Nut	夹线螺母	1	
25	Spring	夹线弹簧	1	
26	Tension disc presser	松线板	1	
27	Tension disk	夹线板	2	
28	Spring	挑线簧	1	
29	Thread tension bracket	夹线调节座	1	
30	Screw	夹线调节座螺钉	1	
31	Tension release pin	松线钉	1	
32	Washer	夹线螺母止动板	1	
33	O Ring	O型圈	1	
34	Screw	夹线调节座固定螺钉	1	
35	Thread guide	线勾	1	
36	Oil cap	橡皮塞	2	Φ8.8
37	Oil cap	橡皮塞	1	Φ27
38	Oil cap	橡皮塞	1	Φ5.7
39	Thread take-up lever cover	挑线杆护罩	1	
40	Screw	挑线杆护罩螺钉	1	
41	Needle plate	针板	1	
42	Screw	针板螺钉	2	
43	Slide plate	推板	1	
44	Slide plate spring	推板簧	1	
45	Screw	推板螺钉	2	
46	Down thread guide arm	下线勾	1	
47	Bed leg	底板撑杆	4	
48	Washer	弹簧垫圈	4	GB93-87
49	Rear cover	后盖板	1	
50	Rear cover packing	后盖板密封垫片	1	
51	Screw	后盖板螺钉	10	
52	Washer	后盖板螺钉垫片	10	
53	Oil shield plate	小挡油板	1	
54	Screw	小挡油板螺钉	1	
55	Trade mark plate	商标牌	1	
56	Rivet	标牌铆钉	2	GB827-86 2.5×5

2、上轴、竖轴、针杆挑线部件

2. NEEDLE BAR AND THREAD TAKE-UP. ARM SHAFT AND VERTICAL SHAFT MECHANISM

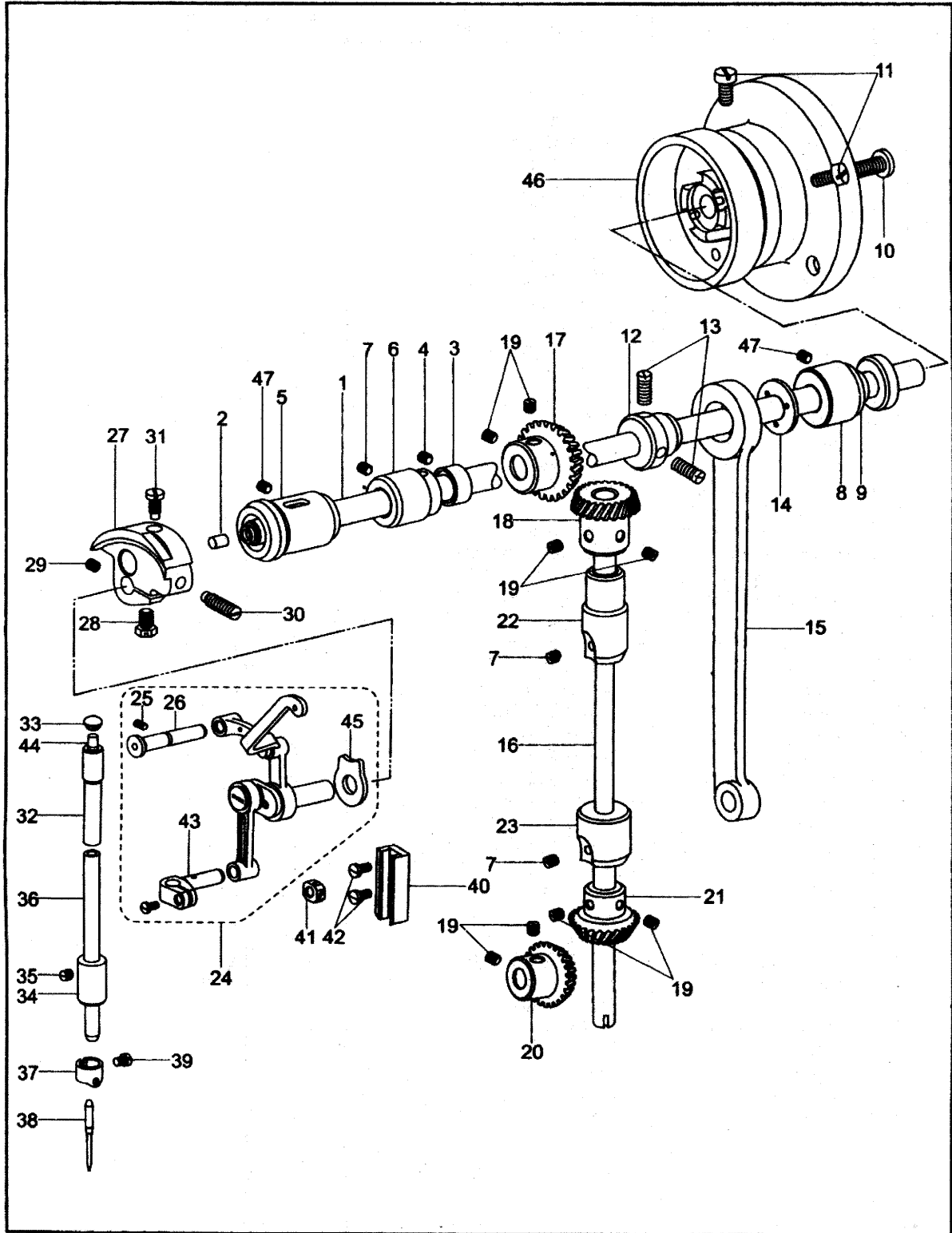

2、上轴、竖轴、针杆挑线部件

2. NEEDLE BAR AND THREAD TAKE-UP, ARM SHAFT AND VERTICAL SHAFT MECHANISM

序号 Ref. No	Description	名 称	数量 Qty	备 注 Memo
1	Arm shaft	上轴	1	
2	Rubber cap	上轴 橡皮塞	2	
3	Copper for arm shaft	上轴紧圈	1	
4	Screw	上轴紧圈螺钉	2	
5	Arm shaft rushing (Left)	上轴前轴套	1	
6	Arm shaft rushing(Middle)	上轴中轴套	1	
7	Screw	中轴、竖轴套螺钉	3	
8	Arm shaft rushing (Right)	上轴后轴套	1	
9	Oil seal	上轴后轴套油封组件	1	
10	Screw	上轴油封螺钉	1	
11	Screw	主动轮螺钉	2	
12	Eccentric wheel	抬牙凸轮	1	
13	Screw	抬牙凸轮螺钉	3	
14	Thrust collar	凸轮隔离片	1	
15	Connecting rod	抬牙连杆	1	
16	Vertical shaft	竖轴	1	
17	Bevel gear for arm shaft	上轴伞齿轮	1	
18	Bevel gear for vertical shaft(up)	竖轴伞齿轮(上)	1	
19	Screw	伞齿轮螺钉	8	
20	Bevel gear for hook shaft	下轴伞齿轮	1	
21	Bevel gear for vertical shaft(low)	竖轴伞齿轮(下)	1	
22	Vertical shaft bushing(Up)	竖轴轴套(上)组件	1	
23	Vertical shaft bushing (low)	竖轴轴套(下)组件	1	
24	Thread take-up lever assy	针杆连杆挑线杆大组件	1	
25	Screw	挑线连杆铰链轴螺钉	1	
26	Hinge pin	挑线连杆铰链轴	1	
27	Needle bar crank	针杆曲柄	1	
28	Screw	挑线曲柄螺钉	1	
29	Screw	挑线曲柄定位螺钉	1	
30	Screw	针杆曲柄螺钉	1	
31	Screw	针杆曲柄定位螺钉	1	
32	Needle bar bushing (up)	针杆上轴套	1	
33	Rubber plug	针杆上轴套橡皮塞	1	Φ8.8
34	Needle bar bushing (low)	针杆下轴套	1	
35	Screw	针杆下轴套螺钉	1	
36	Needle bar	针杆	1	
37	Thread guide	针杆过线环	1	
38	Needle	机针	1	DP×17
39	Screw	夹针螺钉	1	
40	Guide for slide block	针杆接头滑块导轨	1	
41	Slide block	针杆接头滑块	1	
42	Screw	滑块导轨螺钉	2	
43	Needle bar adaptor	针杆接头	1	
44	Felt plug	毛毡	1	
45	Washer	垫片	1	
46	Balance wheel	主动轮	1	
47	Screw	上轴套螺钉	1	

3、抬牙送布勾线部件 FEED AND FEED LIFTING AND ROTATING HOOK MECHANISM

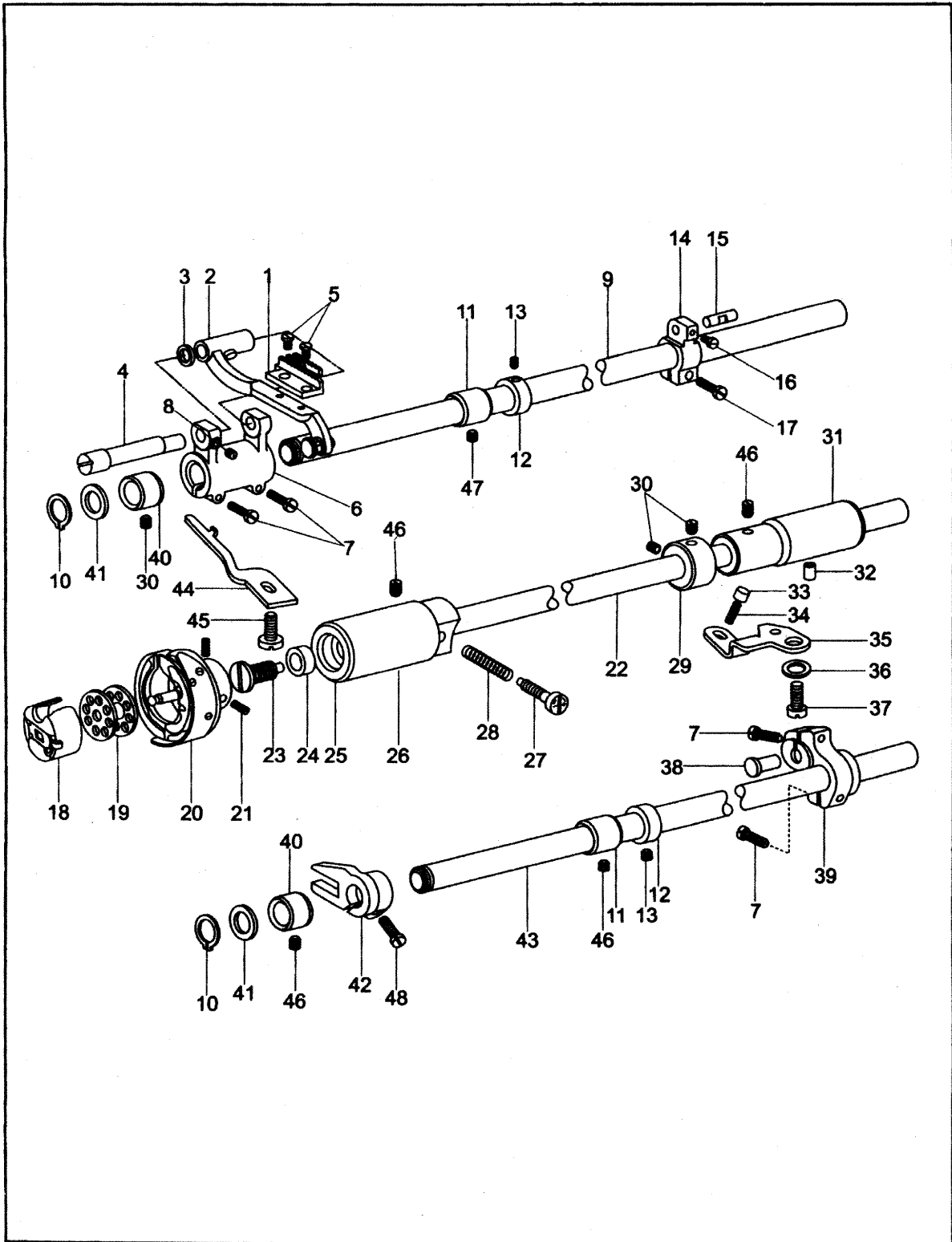

3、抬牙送布勾线部件 FEED AND FEED LIFTING AND ROTATING HOOK MECHANISM

序号 Ref. No	Description	名 称	数量 Qty	备 注 Memo
1	Feed dog	送布牙	1	
2	Feed bar asm	牙架小组件	1	
3	Washer	牙架垫圈	1	
4	Shaft for feed bar	牙架曲柄偏心轴	1	
5	Screw	送布牙螺钉	2	
6	Feed rock shaft crank	牙架曲柄	1	
7	Screw	曲柄螺钉	4	
8	Screw	牙架曲柄轴螺钉	1	
9	Feed rock shaft	送布轴	1	
10	C-Type stop ring	轴用弹性挡圈	2	GB894-76
11	Bushing for feed rock shaft	抬牙、送布轴中轴套	2	
12	Set collar	抬牙、送布轴紧圈	2	
13	Screw	紧圈螺钉	4	
14	Feed rock shaft crank (Right)	送布轴曲柄(右)	1	
15	Hinge pin	曲柄连杆短销	1	
16	Screw	曲柄连杆短销螺钉	1	
17	Screw	曲柄连杆短销夹紧螺钉	1	
18	Bobbin case	梭心套组件	1	
19	Bobbin	梭心	1	
20	Rotating hook complete	旋梭组件	1	
21	Screw	旋梭螺钉	3	
22	Rotating hook shaft	下轴	1	
23	Filter screw	下轴滤油螺钉	1	
24	Filter	下轴滤油塞	1	
25	Oil seal for hook shaft	下轴油封	1	
26	Hook shaft bushing (Left)	下轴前轴套	1	
27	Oil ad tusting screw	油量调节螺钉	1	
28	Spring for oil ad tusting	油量调节弹簧	1	
29	Coller for hook shaft	下轴紧圈	1	
30	Screw	下轴紧圈螺钉	3	
31	Hook shaft bushing(Right)	下轴后轴套	1	
32	Oil pipe	下轴轴套油管	1	
33	Plunger	柱塞	1	
34	Plunger spring	柱塞弹簧	1	
35	Guide plate	挡板	1	
36	Washer	挡板螺钉弹簧垫圈	1	GB894-76
37	Screw	挡板螺钉	1	
38	Hinge pin	抬牙轴曲柄铰链轴	1	
39	Feed lifting rock shaft crank(Right)	抬牙后曲柄	1	
40	Bushing for feed rock shaft	抬牙、送布轴前轴套	2	
41	Washer	抬牙轴前轴套垫圈	2	
42	Fork crank	抬牙叉	1	
43	Feed driving shaft	抬牙轴	1	
44	Rotating hook positioner	旋梭定位勾	1	
45	Screw	旋梭定位勾螺钉	1	
46	Screw	抬牙、下轴轴套螺钉	4	
47	Screw	送布轴套螺钉	1	
48	Screw	抬牙叉夹紧螺钉	1	

4、送布调节部件 STITCH LENGTH REGULATING MECHANISM

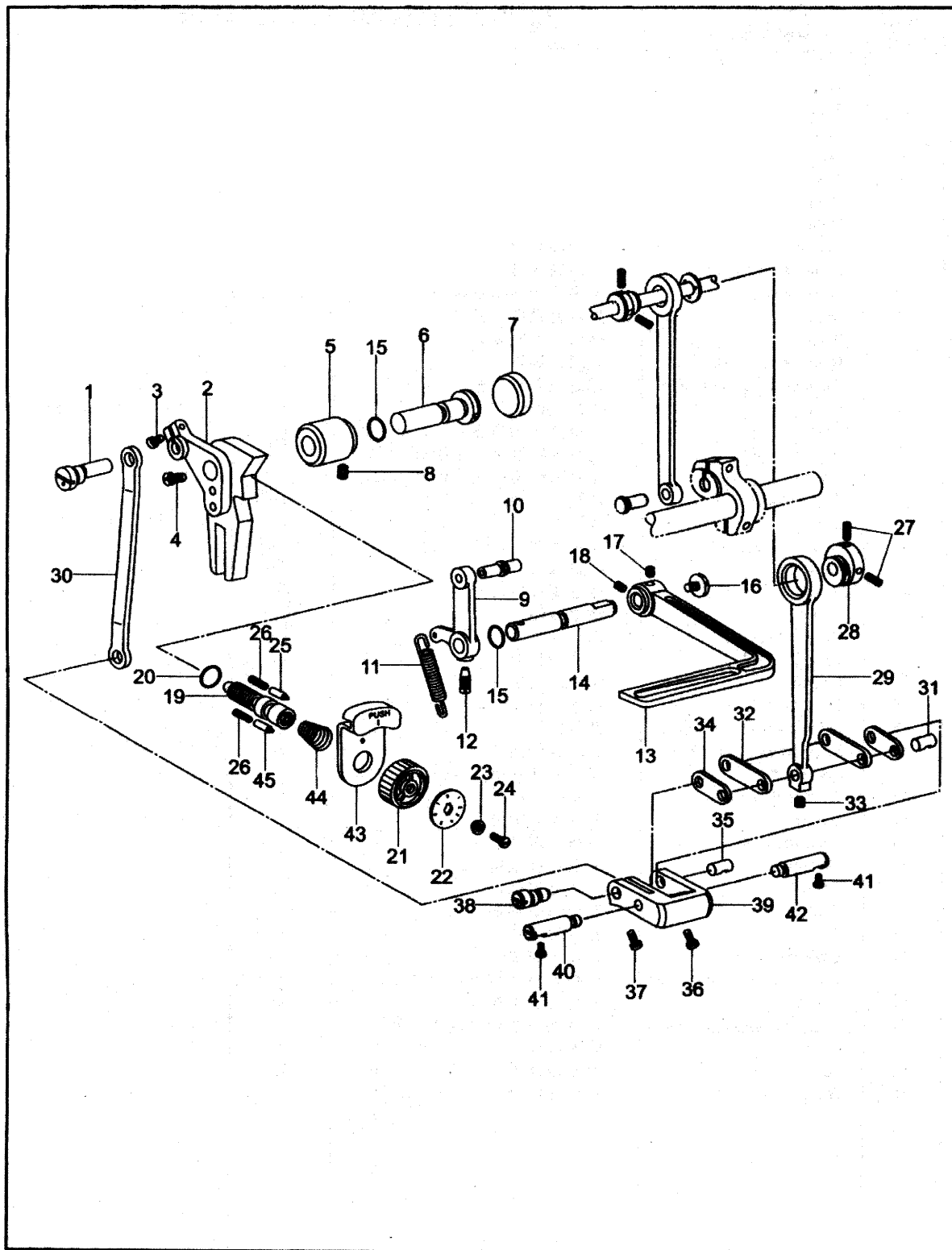

4、送布调节部件 STITCH LENGTH REGULATING MECHANISM

序号 Ref. No	Description	名 称	数量 Qty	备 注 Memo
1	Hinge pin	针距调节连杆销钉	1	
2	Feed regulator	针距座	1	
3	Screw	针距座长螺钉	1	
4	Screw	针距座短螺钉	1	
5	Feed regulator bushing	针距座衬套	1	
6	Hinge pin for regulator	针距座轴	1	
7	Rubber plug	橡皮塞	1	φ20
8	Screw	针距座衬套紧固螺钉	1	
9	Reverse feed crank	倒缝操纵杆曲柄	1	
10	Slide block pin arm	操纵杆曲柄滚柱组件	1	
11	Spring	操纵杆曲柄弹簧	1	
12	Screw	操纵杆曲柄螺钉	1	
13	Reverse feed lever	倒缝操纵杆	1	
14	Reverse feed lever shaft	倒缝操纵杆短轴	1	
15	O Ring	O型密封圈	2	8×1.9 GB1235
16	Screw	倒缝操纵吊紧螺钉	1	
17	Screw	反向送料扳手定位螺钉	1	
18	Screw	反向送料扳手支头螺钉	1	
19	Adjust screw	针距调节螺杆	1	
20	O Ring	O型密封圈	1	14×2.4 GB1235
21	Needle gauge dial	针距盘	1	
22	Mark	针距标盘	1	
23	Washer	标盘螺钉衬套	1	
24	Screw	针距盘螺钉	1	
25	Positioning pin	止动销	1	
26	Spring	止动销弹簧	1	
27	Screw	送布凸轮螺钉	2	
28	Feed drive cam	送布凸轮	1	
29	Level feed connecting rod	送布连杆	1	
30	Feed connecting link	针距调节连杆	1	
31	Link shaft	曲柄连杆长销	1	
32	Feed rock asm link	曲柄长连杆	2	
33	Screw	曲柄连杆螺钉	1	
34	Feed rock link	曲柄短连杆	2	
35	Link shaft	曲柄连杆短销	1	
36	Screw	短连杆销螺钉	1	
37	Screw	连杆偏心轴螺钉	1	
38	Pin	连杆偏心轴	1	
39	Level regulator	针距调节曲柄	1	
40	Adjusting link fulcrum shaft(Left)	针距调节曲柄定位销(左)	1	
41	Screw	左右定位销螺钉	2	
42	Adjusting link fulcrum shaft(Right)	针距调节曲柄定位销(右)	1	
43	Knob	针距按键	1	
44	Spring	针距按键簧	1	
45	Stopper pin	针距盘挡销	1	

5、压脚部件 PRESSER LIFTING MECHANISM

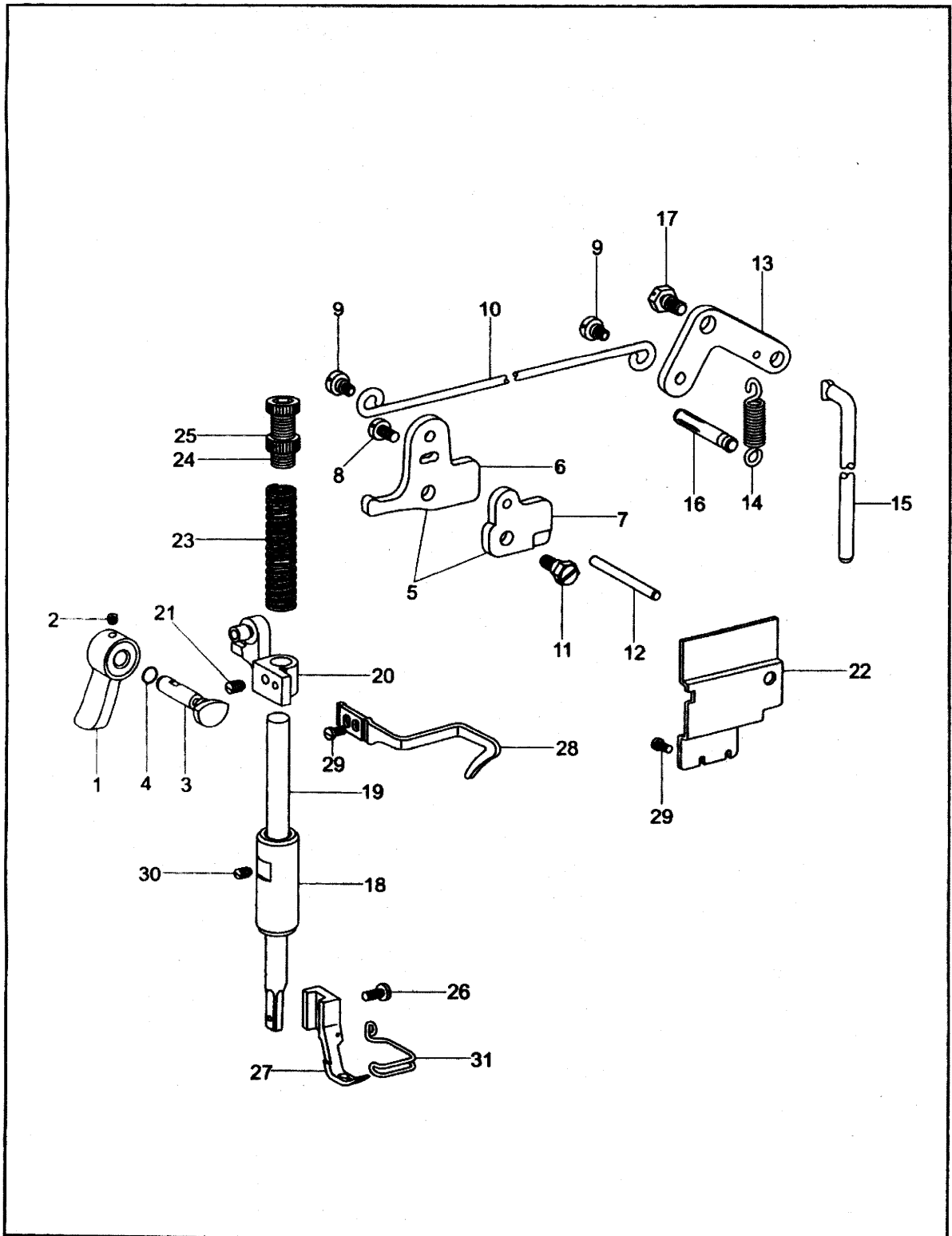

5、压脚部件 PRESSER LIFTING MECHANISM

序号 Ref. No	Description	名 称	数量 Qty	备 注 Memo
1	Presser bar lifter	压脚扳手	1	
2	Screw	压脚扳手螺钉	1	
3	Presser bar lifter cam	压紧杆提升凸轮	1	
4	O Ring	压紧杆提升凸轮油封	1	8×1.9 GB1235
5	Knee lifter lever (Left) asm	膝控提升杠杆（左）组件	1	
6	Knee lifter lever (Left)	膝控提升杠杆（左）	1	
7	Tension releasing	松线凸轮	1	
8	Screw	膝控提升杠杆（左）螺钉	1	
9	Screw	铰链螺钉	2	
10	Bolt	膝控提升拉杆	1	
11	Screw	松线凸轮螺钉	2	
12	Tension releasing pin	松线杆	1	
13	Knee lifter lever (Right)	膝控提升杠杆（右）	1	
14	Spring	膝控提升杠杆（右）弹簧	1	
15	Knee lifter connecting rod	膝控提升连杆	1	
16	Pin	弹簧销	1	
17	Screw	膝控提升杠杆（右）螺钉	1	
18	Presser bar bushing	压紧杆轴套	1	
19	Presser bar	压紧杆	1	
20	Presser bar lifter bracket	压紧杆导架	1	
21	Screw	压紧杆导架螺钉	1	
22	Keep off oil palte	挡油板	1	
23	Spring	压紧杆弹簧	1	
24	Presser regulator screw	调压螺钉	1	
25	Presser regulator nut	调压螺钉锁紧螺母	1	
26	Screw	压脚螺钉	1	
27	Inner presser	小压脚	1	
28	Upper thread guide	大线勾	1	
29	Screw	大线勾螺钉	3	
30	Screw	压紧杆轴套螺钉	1	
31	Finger guard	防护勾	1	

6、上送料部件 PRESSER LIFTING FEEDING MECHNISM

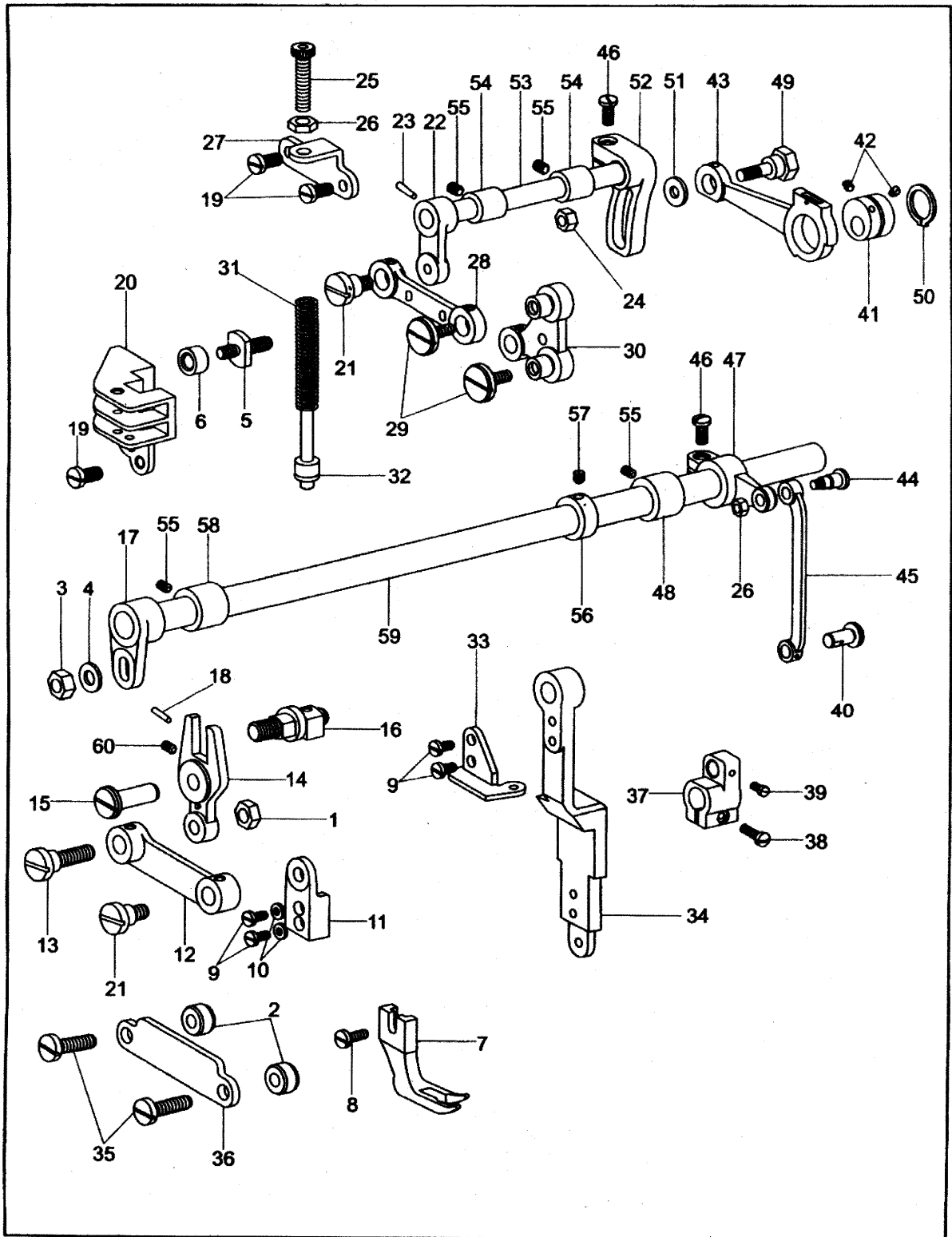

6、上送料部件 PRESSER LIFTING FEEDING MECHNISM

序号 Ref. No	Description	名称	数量 Qty	备注 Memo
1	Nut	压脚送料变动连接螺母	1	
2	Shin	压脚连杆压板垫块	2	
3	Nut	压脚曲柄连接螺母	1	
4	Washer	压脚曲柄连接垫圈	1	GB95-85-6
5	Guide shaft	送料曲柄导柱轴	1	
6	Guide pin	提升压脚导柱轴滚柱	1	
7	Out presser foot	摆压脚	1	
8	Screw	压脚螺钉	1	
9	Screw	摆动连杆座螺钉	4	
10	Washer	摆动连杆座螺钉弹簧垫圈	2	GB95-85-4
11	Presser rod guide	摆压脚杆座	1	
12	Presser swing crank link	摆压脚连杆	1	
13	Screw	压脚送料变动连接螺钉	1	
14	Lifting presser sway crank	摆压脚叉型杆	1	
15	Pin	摆压脚叉型杆销	1	
16	Crank shaft complete	压脚送料变动曲柄轴组件	1	
17	Presser swing crank (left)	压脚摆动前曲柄	1	
18	Pin	圆锥销	1	GB117-86 A4×24
19	Screw	提升压脚导位板螺钉	4	
20	Guide plate	提升压脚导位板	1	
21	Screw	压脚送料曲柄连杆螺钉	2	
22	Presser lifting crank	压脚升降前曲柄	1	
23	Pin	圆锥销	1	GB117-86 A4×20
24	Nut	六角螺母	1	GB173-86-M6×0.75
25	Adjusting screw	摆压脚调压螺钉	1	
26	Adjusting nut	摆压脚调压螺母	2	
27	Bracket adjusting screw	摆压脚调压螺钉架	1	
28	Presser feed crank link	压脚送料曲柄连杆	1	
29	Screw	压脚送料曲柄螺钉	2	
30	Presser feed crank	压脚送料曲柄	1	
31	Spring	摆压脚调压杆弹簧	1	
32	Guide pin	调压杆弹簧导柱	1	
33	Guide plate	提升压脚导柱定位板	1	
34	Presser lever	摆压脚杆	1	
35	Screw	提升压脚连接压板螺钉	2	
36	Presser plate	提升压脚连接压板	1	
37	Feed rock shaft crank	送布轴曲柄(中)	1	
38	Screw	送布轴曲柄(中)螺钉	1	
39	Screw	大连杆曲柄连接销钉	1	
40	Pin	大连杆曲柄连接销	1	
41	Eccentricity wheel	压脚升降偏心轮	1	
42	Screw	螺钉	2	
43	Eccentricity wheel link	连杆组件	1	
44	Screw	压脚摆动后曲柄连杆螺钉	1	
45	Link	摆压脚大连杆	1	
46	Screw	偏心连杆调节曲柄螺钉	2	
47	Pear crank	压脚摆动后曲柄	1	
48	Pear crank bushing	压脚摆动轴后轴套	1	
49	Screw	偏心轮连杆螺钉	1	
50	C-Type stop ring	轴用C型挡圈	1	GB894-86-25
51	Washer	垫圈	1	
52	Link adjusting crank	偏心连杆调节曲柄	1	
53	Presser lifting shaft	压脚升降轴	1	
54	Shaft bushing	摆压脚提升轴套	2	
55	Screw	摆动升降轴套支头螺钉	4	
56	Set collar	压脚摆动轴紧圈	1	
57	Screw	压脚摆动轴紧圈螺钉	2	
58	Bushing	压脚摆动轴前轴套	1	
59	Presser foot swing shaft	压脚摆动轴	1	
60	Screw	摆压脚叉型杆销螺钉	1	

7、油泵部件 LUBRICATION MECHANISM

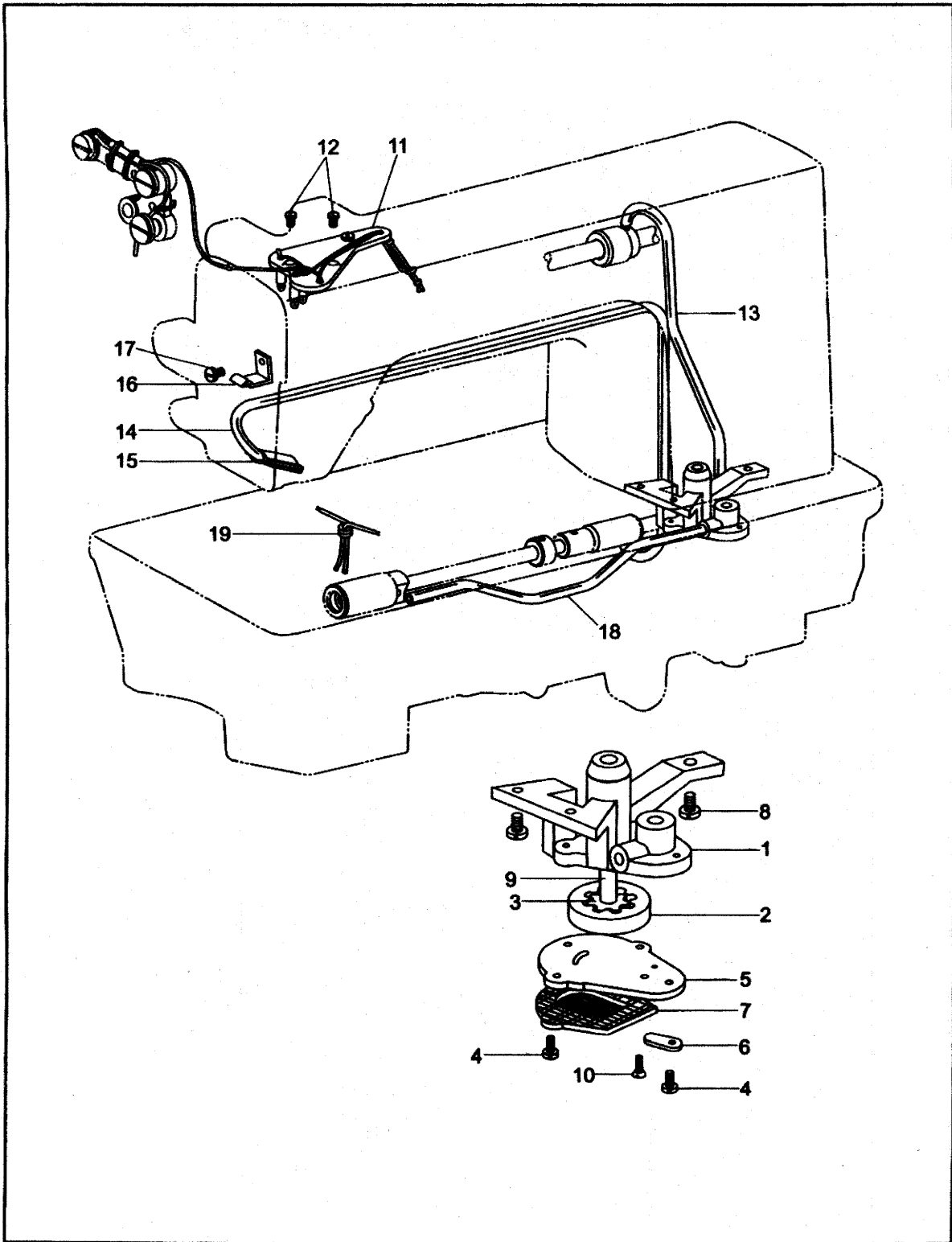

7、油泵部件 LUBRICATION MECHANISM

序号 Ref. No	Description	名 称	数量 Qty	备 注 Memo
1	Oil pump body	油泵体	1	
2	Oil pump impeller (big)	油泵大齿轮	1	
3	Oil pump impeller(small)	油泵小齿轮	1	
4	Screw	螺钉	3	M3×10 GB67-85
5	Oil pump pin guide plate	油泵体盖板	1	
6	Oil adjust plate	油泵调节板	1	
7	Oil pump screen plate	油泵滤网组件	1	
8	Screw	油泵体螺钉	3	
9	Oil pump boby shaft	油泵体短轴	1	
10	Screw	油泵体盖板螺钉	2	M3×10GB68-85
11	Oil braid fitting plate	油线固定板大组件	1	
12	Screw	油线固定板螺钉	2	
13	Oil pipe for asm shaft	上轴油管组件	1	
14	Oil return pipe	回油管	1	
15	Felt pouch	回油管滤油毡	1	
16	Pipe hold	回油管夹	1	
17	Screw	回油管螺钉	1	
18	Oil pipe for hook shaft	下轴油管组件	1	
19	Oil wik	油线	2	

8. 附件 ACCESSORIES

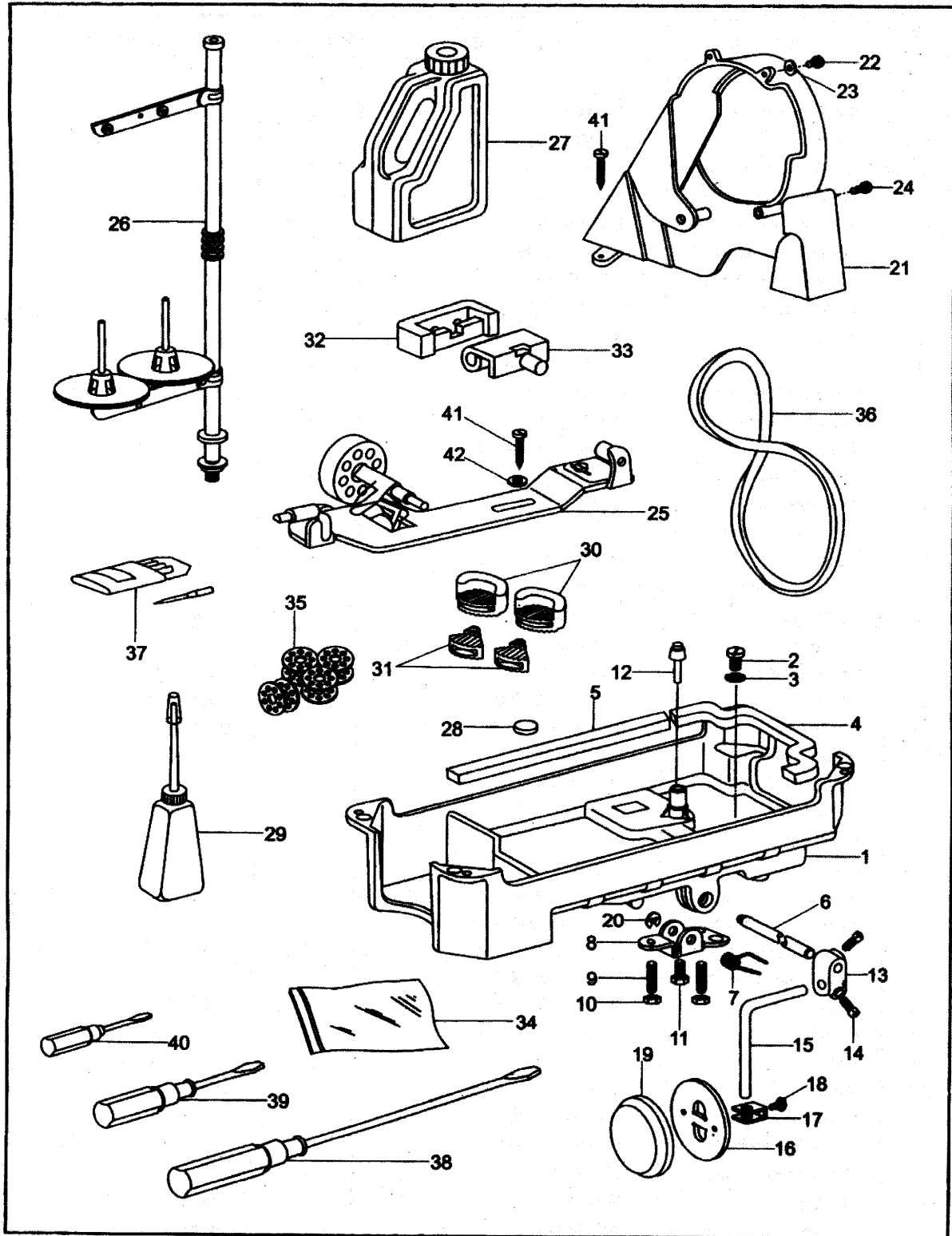

8: 附件 ACCESSORIES

序号 Ref. No	Description	名 称	数量 Qty	备 注 Memo
1	Oil reservoir	油盘	1	
2	Oil drain screw	放油螺钉	1	
3	Washer	放油螺钉垫圈	1	
4	Gasket for oil reservoir (Small)	油盘垫 (小)	1	
5	Gasket for oil reservoir (Big)	油盘垫 (大)	1	
6	Hinge pin for knee lifter	膝控铰链轴	1	
7	Back spring for knee lifter	膝控复位弹簧	1	
8	Knee lifter stop bracket	膝控限位架	1	
9	Adjusting screw	膝控限位调节螺钉	2	
10	Lock nut	调节螺母	2	
11	Screw	膝控限位架螺钉	1	
12	Knee lifter lifting rod	膝控提升顶杆	1	
13	Joint knee lifer bell crank	碰块弯杆接头	1	
14	Screw	碰块弯杆接头螺钉	2	
15	Knee lifter bell crank	膝控碰块弯杆	1	
16	Knee lifter plate	膝控碰块	1	
17	Bracket for knee lifter plate	碰块架	1	
18	Screw	碰块架螺钉	1	
19	Pad for knee lifter plate	碰块垫	1	
20	Retaining ring	开口挡圈	1	GB896-76
21	Belt cover case asm	皮带罩组件	1	
22	Screw (Small)	皮带罩螺钉 (小)	2	M4×8 GB67-85
23	Washer	皮带罩螺钉垫圈	2	GB848-85-4
24	Screw (big)	皮带罩螺钉 (大)	2	M5×12GB67-85
25	Bobbin winder asm	绕线器组件	1	
26	Thread stand asm	线架组件	1	
27	Oil contaier	油箱	1	
28	Magent	磁块	1	
29	Oiler	小油壶	1	
30	Rubber cushion (Big)	机头防震垫块 (大)	2	
31	Rubber cushion (Small)	机头防震垫块 (小)	2	
32	Rubber socket for hinge	连接勾防震外护套	2	
33	Hinge of machine head	机壳抬板连接勾	2	
34	Bag	零件袋	1	
35	Bibbin	梭芯	5	
36	Belt	三角皮带	1	
37	Needle	机针	1包 (big)	DP×17.
38	Screw driver (Big)	螺钉起子 (大)	1	
39	Screw driver (Middle)	螺钉起子 (中)	1	
40	Screw driver (Small)	螺钉起子 (小)	1	
41	Wood screw	绕线器自攻螺钉	4	GB5282-85 ST4.8×19
42	Washer	绕线器螺钉垫圈	2	GB848-85-6